

CB04-18

鉻酸過濾機

CHROMIC ACID FILTER

▶ 特點及優點

1. 使用溫度45°C以下。
2. 本過濾機採用PVC材質製成，可耐鉻酸液及各種酸鹼液體。
3. 泵浦採用PVDF材質製成，可選用自吸式泵浦與磁力泵浦。
4. 濾材採用鎖螺型，密封性好，濾桶內無金屬材質接觸藥水。
5. 標準配備：底閥、法蘭及法蘭墊片、螺絲。

▶ Features and benefits

1. Usage temperature is below 45 °C.
2. The filter is made of PVC material, which can be resistant to chromic acid and a variety of acid and alkaline liquid.
3. The pump is made of PVDF material. Self-priming pump and magnetic pump are optional.
4. Lock filter element type of filter materials is adopted, with good sealing performance; no metal texture is exposed to liquid in the filter body.
5. Standard accessories: foot valve, flange and flange gasket and screw.



型號說明 MODEL IDENTIFICATION

CB 2018 KD F 50 3 2 U E D

1 2 3 4 5 6 7 8 9 10 11

1. 機型編號 Model

C—一體成型過濾機 Integrated filter

2. 濾材形式 Filter Type

B—濾芯鎖螺型 Lock filter element type

3. 濾材規格 Filter Specifications

濾芯(Core): 2018-20inch(長度)X18支(數量)(Length X Quantity)

2004-20"X4pcs 2006-20"X6pcs

2012-20"X12pcs 2018-20"X18pcs

4. 泵浦型式 Pump Type

ME—磁力泵 Magnetic Pump

KD—自吸泵 Self-priming Pump

KD—自吸泵 Self-priming Pump

MED—非自吸式 Non Self-priming Pump

5. 泵浦材質 Pump Body

F—PVDF

6. 出入口徑 Inlet And Outlet Diameter

40-1-1/2" 50-2"

7. 泵浦馬力 Pump Power

D-260W 0-0.5HP 1-1HP 2-2HP 3-3HP

8. 極數 Pole

2-2P

9. 出入口形式 Outlet And Inlet Type

U—由任式 Union F—法蘭式 Flange

10. 密封材質 Seal

V—VITON

11. 出入口標準 Outlet And Inlet Specifications

J—JIS D—DIN A—ANSI

CB04-18

鉻酸過濾機

▶ 尺寸圖 Dimensions

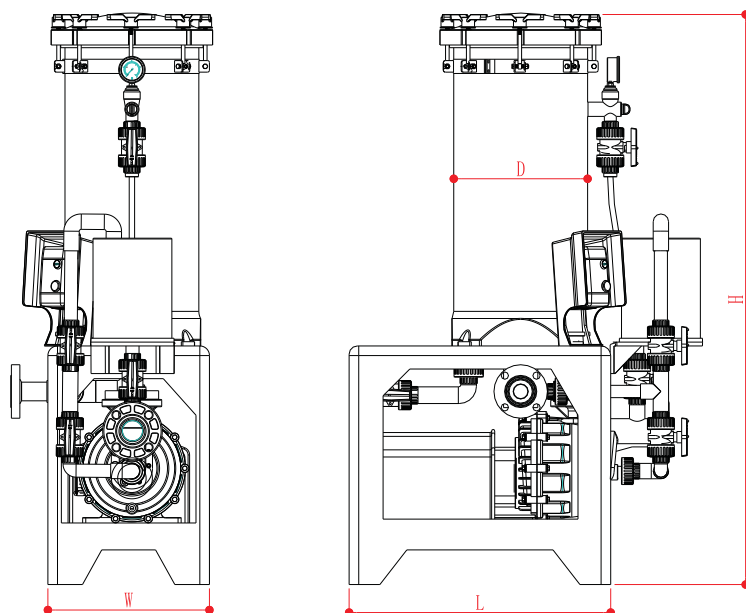

型式Model	L	W	H	D
CB2004	455.0	345.0	1180.0	220.0
CB2006	680.0	400.0	1460.0	280.0
CB2008	680.0	455.0	1490.0	315.0
CB2012	680.0	455.0	1490.0	350.0
CB2018	700.0	560.0	1540.0	450.0

▶ 規格表 Specifications

型式Model	濾材Filter Material	過濾面積 Filter Area (m ²)	過濾量Filter Capacity (l/min)	適合電鍍槽 Plating Tank Volume(l)	適用溫度 Temperature (≤℃)	泵浦功率 Pump Power(HP)	口徑Diameter (in-out)inch	機器重量 Weight(kg)
CB2004	20"x4	1	80	0.6	65	0.3	1"x1"	40
CB2006	20"x6	1.5	160	1-2	65	1	1.5"x1.5"	90
CB2008	20"x8	2	240	1-3	65	1	1.5"x1.5"	100
CB2012	20"x12	3	330	2-4	65	2	1.5"x1.5"	110
CB2018	20"x18	4.5	375	4-6	65	3	2"x2"	130