

CHH06-18

多功能可切換雙桶過濾機

MULTIFUNCTION SWITCHABLE DOUBLE-BARREL FILTER

► 特點及優點

- 1.功能：單桶過濾、雙桶串聯過濾（過濾精度高）
雙桶並聯過濾（過濾量大）。
- 2.可在工作狀態下更換濾芯，提高工作效率。
- 3.主體桶採用PP材料一體射出成型，堅固耐用、不洩漏、耐高溫及耐酸鹼。
- 4.濾材組立式設計，各部件更換容易，並可根據客戶要求隨時更換。
- 5.泵浦可採用自吸式泵和無軸封磁力泵等多種選擇。
- 6.標準配備：底閥、法蘭及法蘭墊片，PVC 螺絲，SUS螺絲。

► Features & Advantages

- 1.Function: single barrel filtration, double barrel series filtration (high filter fineness), double barrel parallel filtration (large filtration volume).
- 2.Filter element can be changed while working to increase the work efficiency.
- 3.The filter body is made by the injection molding of the PP material, which is more durable, resistant to high temperature and acid and alkaline, without leakage.
- 4.Vertical design of the filter material assembly makes the components easily be replaced at any time according to customer requirements.
- 5.Self-priming pump and magnetic pump without shaft seal and others are all optional.
- 6.Standard accessories: foot valve, flange and flange gasket, PVC screws and SUS screws.



型號說明 MODEL IDENTIFICATION

CHH 5928-2018 KD P 50 3 2 F E D

1 2 3 4 5 6 7 8 9 10 11 12 13

1.機型編號 Model

C-一體成型過濾機 Integrated filter

2-3.濾材形式 Filter Type

B-濾芯鎖螺型 Lock filter element type

H-濾芯壓板型 Pressure filter element type

P-濾紙型 Filter paper type

K-楊桃濾布型 Bellow filter cloth type

4-5.濾材規格 Filter Specifications

濾芯(Core):2018-20inch(長度)X18支(數量)(Length X Quantity)

2012-20"X12pcs

2018-20"X18pcs

3018-30"X18pcs

濾片(Disc) :4524-45cm(長度)X24片(數量) (Length X Quantity)

4524-45cmX24pcs

5928-59cmX28pcs

6.泵浦型式 Pump Type

ME-磁力泵 Magnetic Pump

KD-自吸泵 Self-priming Pump

KDN-自吸泵 Self-priming Pump

MED-非自吸式 No Self-priming Pump

CHH06-18

多功能可切換雙桶過濾機

7. 泵體材質 Pump Body

P-PP F-PVDF

8. 出入口徑 Inlet And Outlet Diameter

40-1-1/2" 50-2"

9. 泵浦馬力 Pump Power

2-2HP 3-3HP 5-5HP

10. 極數 Pole

2-2P

11. 出入口形式 Outlet And Inlet Type

U-由任式 Union F-法蘭式 Flange

12. 密封材質 Seal

E-EPDM V-VITON N-NBR

13. 出入口標準 Outlet And Inlet Specifications

J-JIS D-DIN A-ANSI

▶ 尺寸圖 Dimensions

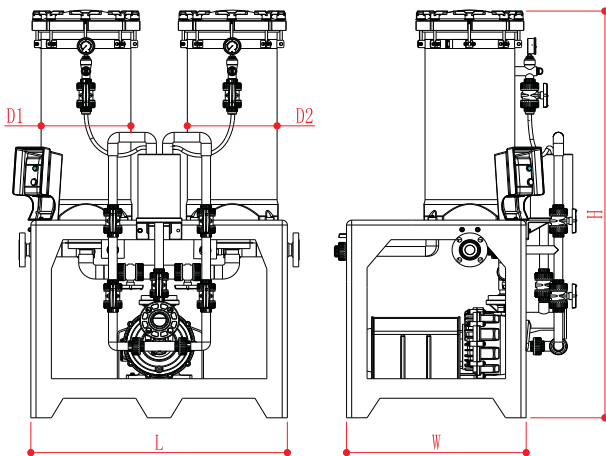

型式 Model	L	W	H	D1	D2
CHH2018-2018	1200.0	700.0	1600.0	450.0	450.0
CKK5928-5928	1200.0	700.0	1600.0	450.0	450.0

▶ 規格表 Specifications

型式 Model	過濾面積 Filter Area (m ²)			過濾量 Filter Capacity (l/min)			適用溫度 Temperature (≤°C)	泵浦功率 Pump Power (HP)	□徑 Diameter (in-out) inch	機器重量 Weight (kg)
	單桶 Single barrel	串聯 Series connection	並聯 Parallel connection	單桶 Single barrel	串聯 Series connection	並聯 Parallel connection				
CHH2018-2018	4.5	9.0	9.0	375	375	480	65	3	2"x2"	180
CKK5928-5928	4.8	9.6	9.6	375	400	480	65	3	2"x2"	180